



Research paper

# Damping Critical Electromechanical Oscillations via Generators Redispatch Considering ZIP Load Model and Transmission Lines Resistance

M. Setareh<sup>\*</sup>, A. Moradibirgani

Faculty of Electrical Engineering, Shahid Beheshti University, Tehran, Iran.

## Article Info

### Article History:

Received 24 October 2024  
Reviewed 12 December 2024  
Revised 18 January 2025  
Accepted 22 January 2025

### Keywords:

Generators redispatch  
Oscillatory modes  
Remedial action  
Sensitivities  
Transmission line resistance  
ZIP load model

<sup>\*</sup>Corresponding Author's Email  
Address: [m\\_setareh@sbu.ac.ir](mailto:m_setareh@sbu.ac.ir)

## Abstract

**Background and Objectives:** This paper proposes a novel formula to calculate the sensitivities of electromechanical modes with respect to generators active power changes. The generic ZIP load model is considered and the effect of various types of loads on the best paradigm of generators redispatch (GR) is investigated. Furthermore, transmission lines resistance are modeled in the proposed formulae; and the best GR schemes to improve the power system damping with considering and neglecting transmission lines resistance are compared.

**Methods:** Four energy functions are defined and the quadratic eigenvalue problem is applied to construct the framework of the proposed formula. The dynamic equation of the classical model of synchronous generators along with algebraic equations of power network considering transmission lines resistance and ZIP model of power system loads are written in a systematic manner using the partial differential of the energy functions. Then, set of equations of the power system are linearized and sensitivity factors are calculated using power system model parameters and power flow variables, which can be either obtained via state estimation or measured directly by phasor measurement units.

**Results:** The 39-bus New England power system is used to calculate sensitivities. The value of Sensitivity factors in conditions of considering transmission lines resistance and neglecting ones are compared and then the best GR plan to improve critical damping is determined. If all the loads are assumed to be in constant power mode, then for two modes with and without considering transmission lines resistance, generators pairs (9,1) and (5,2) are the best redispatch plans to damp oscillations. However, If all the loads are assumed to be in constant current mode, the best generators pair without considering transmission lines resistance mode does not change, although, it changes to generators pair (5,1) for the mode of considering transmission lines resistance.

**Conclusion:** Using the classical model of synchronous generators does not give information about the damping-ratio of the inter-area mode and only estimates its frequency well. Besides, considering the load model and resistance of transmission lines change the best paradigm of GR to suppress oscillations.

This work is distributed under the CC BY license (<http://creativecommons.org/licenses/by/4.0/>)



## Introduction

Maintaining the small signal stability is a vital issue in the operation of power systems. Fig. 1 portrays the

classification of strategies, methods, tools, and criteria for improving the small signal stability of power system. As seen in this figure, the corresponding strategies are

divided into twofold: 1) equipment-based [1] and 2) remedial actions [2]. Their primary distinction is that the first category controllers are always in service, whereas corrective actions are applied to the system as needed.

Besides, remedial actions usually impose additional costs on the operating power system, whereas the costs associated with applying the first strategy pertain to the expansion planning of the power system.

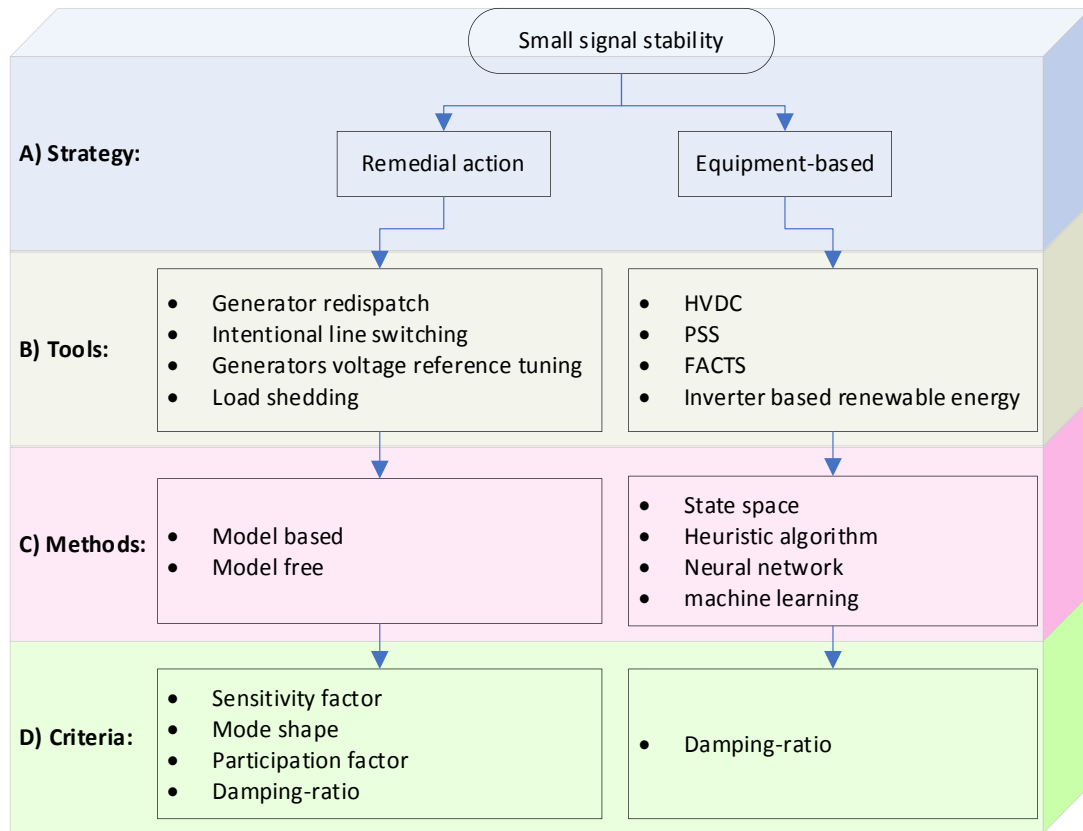

Fig. 1: Power system small signal stability improvement. A) strategies, B) tools, C) methods, and D) criteria.

In the equipment-based category, various mathematical methods such as state space, transfer function, and heuristic algorithms have been applied to tune the parameters of controllers. The most popular device in this category is the power system stabilizer (PSS) installed next to the generator excitation system [3]. This electronic equipment has lead-lag blocks to provide phase compensation. Setting the parameters of these blocks requires detailed studies, and therefore it is accomplished offline. Meta-heuristic algorithms such as genetic algorithm [4], particle swarm optimization [5], chaotic bat algorithm [6], and adaptive rat swarm [7] were applied to determine the PSS parameters. The industrial application of this equipment is mainly limited to damp local electromechanical oscillations. However, synchronized wide-area signals were used to extend the performance of PSS for damping inter-area oscillations [8], [9]. Nevertheless, power network controllers i.e. HVDC, and flexible AC transmission system (FACTS) equipped with a converter are more efficient for suppressing inter-area oscillations. Because they can be installed in the substations connected to transmission tie-lines.

The authors in [10] used model predictive control for tuning parameters of HVDC controllers, and in [11], augmented random research was applied to do so. Static var compensator (SVC) [12], static compensators (STATCOM) [13], and thyristor Controlled Series Capacitor (TCSC) [14] are more applicable FACTS devices to improve power system small signal stability. SVC and TCSC provide instantaneous reactive power support to the connected power system and help to dampen electromechanical oscillations by controlling the voltage of the point of common coupling with the power grid. However, STATCOM can suppress power oscillations by exchanging active and reactive powers with the power grid.

With the proliferation of renewable sources in smart power systems, their penetration has reached such a level that they can play an important role in power system stability. These resources are mainly connected to the power network through a converter. Therefore, applying auxiliary power oscillation damping controllers which produce a proper modulation signal for the grid-connected Inverter of renewable resources has been given special attention [15]-[17]. Authors in [18] designed

optimal probabilistic robust damping controllers to suppress multiband oscillations in the power system integrated with wind farms using adaptive compass search. The authors in [19] developed a coordinated control scheme for utility-scale photovoltaic and wind power plants to suppress electromechanical oscillations while maintaining voltage stability.

The controllers in the equipment-based strategy are tuned for a specific power system operating point. Therefore, their efficacy drastically deteriorates at out-of-range operating points, and remedial actions in this situation can be applied. Because optimal remedial actions are determined based on power system operation conditions and can be applied whenever needed.

The frequency of electromechanical oscillations is usually in the range of 0.1 Hz to 1.5 Hz [2]. Therefore, there is enough time to perform remedial measures to improve the damping of the power system. The application of online remedial measures in nowadays modern power systems is growing due to the proliferation of measurement instrument installation i.e. phasor measurement units (PMU), as well as the emergence of more powerful processors. PMU can send measured data at a rate of several tens of Hz to the power system control center, and therefore proper situational awareness of the real-time condition of the power system can be gained. [20], [21]. Therefore, proactive remedial measures to improve the operating conditions of the power system can be used online [22]. Nonetheless, remedial actions can be used either preventively or correctively. If appropriate measures are taken to improve the operational conditions before any event occurs, remedial measures are preventive. The measures taken after the incident to rescue the system from instability are referred to as corrective measures. Since the power system is non-linear, its small signal characteristics vary when the operating point changes via applying remedial actions. GR [23]-[29], transmission lines switching [30], load shedding [25], and voltage reference tuning of generators [31] are remedial actions introduced in the literature. However, GR is a more applicable remedial action to suppress low-damp electromechanical oscillations.

The best remedial actions to achieve the preset aim have been determined in the literature through two methods: 1) model-based [32] and 2) model-free [33]. In the first method, sensitivity factors of the power system with respect to remedial actions are determined analytically. Direct calculation of the amplitude of remedial measures is the main pros of these methods. However, the need for an accurate system model is a disadvantage. In model-free methods, measurement data is used, and therefore, the need for a valid database is one of the limitations of these methods. Besides, they cannot estimate sensitivity factors directly. The usually use criteria such as participation factors and mode shape to

specify the best remedial actions [34].

In [23], generators active power sensitivity factors were used to determine optimal power flow (OPF). To do so, first- and second-order sensitivities of critical eigenvalues with respect to OPF variables were calculated. Authors in [24] used aperiodic small signal rotor angle stability assessment strategy to detect unstable power system operation, and GR was applied such that the critical generator backs into the secure region. In [25], OPF for achieving an appropriate security level in terms of small-signal rotor angle stability was applied. To do so, sensitivity factors with respect to GR have been calculated by a repetitive approach. Critical incidents were recognized in terms of security margin and the operating points of energy resources and consumers were determined considering the cost of generation variations and load decrement.

Authors in [26] processed synchronized wide area signals using independent component analysis along with random decrement technique to estimate damping-ratio of critical oscillatory modes. An iterative algorithm was used to determine required changes of generators active power for improving the critical inter-area mode damping. Mode shape index was applied to specify the most effective generators pair for redispatching. Then, their active power was changed step by step. At each step, the damping-ratio of the critical electromechanical mode was estimated using the algorithm of random decrement. This process is repeated until the desired damping is reached. In [27], analytical formulae were proposed for model-based modal analysis. Second-order synchronous generators dynamic model was used and corresponding equations were organized in the form of the quadratic eigenvalue problem (QEP). Lossless transmission lines and constant active power loads were considered, and sensitivity factors related GR for improving damping-ratio of oscillatory modes were calculated.

Iterative-based method for GR sensitivity factors calculation was applied in [28]. Sensitivity factors were specified by standard modal analysis in both conditions of before and after changing generators active power. At each iteration, the active power of generators has been changed optimally using sensitivity factors. This process continues until the minimum damping constraint is met. Likewise, authors in [29] proposed a sequential GR to damp low-frequency oscillations. An analytical model-based manner based on normalized participation factors (NPF) was presented to determine an effective GR scheme for improving power system damping. NPF was calculated as an indicator of sensitivity factors.

In [30] a list of effective transmission lines switching was arranged offline. To do so, modal analysis was performed after each transmission line switching, and the

damping-ratio changes of critical electromechanical modes were calculated. Since transmission line switching may cause a violation of the system security constraints, an optimization algorithm for determining the required generators active power and load shedding was used.

Voltage reference tuning of generators is a cost-free remedial action and its efficacy in suppressing electromechanical oscillations was investigated in [31]. However, this study needs the synchronous generator dynamic model comprising the field winding and the excitation system.

The implementation of online remedial measures is a relatively new strategy that has become feasible by the intelligentization of power systems. This advancement has spurred researchers to calculate various indices for identifying the effective remedial actions on enhancing the performance of the power system. Sensitivity coefficients represent accurate information for this purpose. In this paper, we develop our previous research in [35] to take into account the generic ZIP load model along with the resistance of transmission lines for calculating sensitivity factors of electromechanical modes using a systematic method. The dynamic-algebraic equations (DAE) of the power system are arranged in the form of the quadratic eigenvalue problem. Then, they are linearized, and sensitivity factors of oscillatory modes related to the GR remedial action are calculated. The main contributions of this paper are summarized as follows:

- Proposing four energy functions to model the power system linearized DAE by a regular method in the form of QEP.
- Modeling ZIP load model and transmission lines resistance to calculate the sensitivities.
- Scrutinizing the impact of load model and transmission lines resistance to specify the most effective generators redispatches.

The rest of the paper continues as follows. In the next section, four energy functions are proposed to arrange dynamic-algebraic equations of the power system into the form of the quadratic eigenvalue problem. Then, the differential equations are taken and the closed-form equations of sensitivity factors of the electromechanical modes are presented. In the simulation section, IEEE 39 bus test system is used to determine critical mode sensitivities. Finally, the last section concludes the paper and discusses directions for future work.

### Power System Dynamic-Algebraic Equations

Considering the second-order model of synchronous generators and the complete model of the power network, the model of the power system for studying small signal stability is illustrated as shown in Fig. 2. Assuming that the power system has  $m$  generators, buses 1 to  $m$  are internal buses of the generators and other buses  $m + 1$  to  $n$  be load buses.

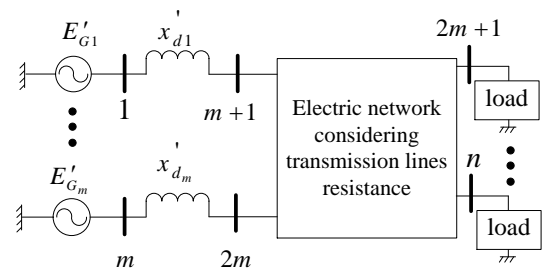

Fig. 2: Power system model.

Equations (1) and (2) exhibit internal buses and other buses active power balance, respectively. Besides, Equation (3) represents reactive power balance equations for non-generator buses [36].

$$\frac{2h_i}{\omega_0} \ddot{\delta}_i + \frac{d_i}{\omega_0} \dot{\delta}_i + G_{ii}V_i^2 + V_i \sum_{\substack{j=1 \\ j \neq i}}^n G_{ij}V_j \cos(\delta_i - \delta_j) + V_i \sum_{\substack{j=1 \\ j \neq i}}^n B_{ij}V_j \sin(\delta_i - \delta_j) = P_{mech_i} \quad i = 1, \dots, m \tag{1}$$

$$G_{ii}V_i^2 + V_i \sum_{\substack{j=1 \\ j \neq i}}^n G_{ij}V_j \cos(\delta_i - \delta_j) + V_i \sum_{\substack{j=1 \\ j \neq i}}^n B_{ij}V_j \sin(\delta_i - \delta_j) = P(V_i) \quad i = m + 1, \dots, n \tag{2}$$

$$\sum_{\substack{j=1 \\ j \neq i}}^n G_{ij}V_j \sin(\delta_i - \delta_j) - \sum_{\substack{j=1 \\ j \neq i}}^n B_{ij}V_j \cos(\delta_i - \delta_j) = B_{ii}V_i + \frac{Q_i(V_i)}{V_i} \quad i = m + 1, \dots, n \tag{3}$$

where  $h_i$  and  $d_i$  are inertia constant in second and damping constant in pu torque/pu speed of the  $i^{th}$  generator.  $G_{ii}$  and  $B_{ii}$  are real and imaginary parts of entry  $i, j$  of  $Y_{bus}$  matrix, respectively. Furthermore,  $P_{mech_i}$ ,  $P(V_i)$  and  $Q(V_i)$  are the input mechanical power of  $i^{th}$  generator and net active and reactive power injections at bus  $i$ , respectively.

Here, power system loads are modeled by the static model which is known as ZIP model. The generic formulation for ZIP load model is equal to [37]:

$$P(V) = P_0 \left( k_{PI} \left( \frac{V}{V_0} \right) + k_{PZ} \left( \frac{V}{V_0} \right)^2 + k_{PC} \right) \tag{4}$$

$$Q(V) = Q_0 \left( k_{QI} \left( \frac{V}{V_0} \right) + k_{QZ} \left( \frac{V}{V_0} \right)^2 + k_{QC} \right) \tag{5}$$

where  $k_{PI}$ ,  $k_{PZ}$ , and  $k_{PC}$  are coefficients of the proportion of constant current, impedance, and power of the active power load. Similarly,  $k_{QI}$ ,  $k_{QZ}$ , and  $k_{QC}$  are the coefficients related to the reactive power load. It is noteworthy that the sum of the coefficients of the different portions of the active power must be equal to 1. The same is true for the reactive power coefficients.

### Organizing Power System Equations in QEP Model

QEP Model is equivalent to a generalized eigenvalue problem. This is a more comprehensive form than the standard state space method. The system equations can be written as a mixture of zero to second-order equations next to each other [38], [39].

Equations (6) to (9) show four proposed energy functions to arrange the power system DAE into QEP model:

$$R^{Pbus} = -\sum_{i=1}^m P_{mech_i} \delta_i - \sum_{i=m+1}^n P(V_i) \delta_i \quad (6)$$

$$R^{Qbus} = -\sum_{i=m+1}^n \left( \frac{1}{2} b_{ii} V_i^2 + Q_{i0} \left( k_{Ql} \frac{V_i}{V_{i0}} + \frac{1}{2} k_{Qz} \left( \frac{V_i}{V_{i0}} \right)^2 + k_{QC} \ln V_i \right) \right) \quad (7)$$

$$R^B = -\sum_{\substack{i,j \\ i \neq j}} B_{ij} V_i V_j \cos(\delta_i - \delta_j) \quad (8)$$

$$R^G = -\sum_{\substack{i,j \\ i \neq j}} G_{ij} V_i V_j \cos(\delta_i - \delta_j) \quad (9)$$

Now, the system equations can be rewritten as:

$$\frac{2h_i}{\omega_0} \ddot{\delta}_i + \frac{d_i}{\omega_0} \dot{\delta}_i + G_{ii} V_i^2 + \frac{\partial^2 R^G}{\partial \delta_i^2} + \frac{\partial R^{Pbus}}{\partial \delta_i} + \frac{\partial R^B}{\partial \delta_i} = 0 \quad i = 1, \dots, m \quad (10)$$

$$G_{ii} V_i^2 + \frac{\partial^2 R^G}{\partial \delta_i^2} + \frac{\partial R^{Pbus}}{\partial \delta_i} + \frac{\partial R^B}{\partial \delta_i} = 0 \quad i = m+1, \dots, n \quad (11)$$

$$\frac{\partial^2 R^G}{\partial V_i \partial \delta_i} + \frac{\partial R^{Qbus}}{\partial V_i} + \frac{\partial R^B}{\partial V_i} = 0 \quad i = m+1, \dots, n \quad (12)$$

The above equations are non-linear, and their linearization leads to the following quadratic differential equations:

$$\frac{2h_i}{\omega_0} \Delta \ddot{\delta}_i + \frac{d_i}{\omega_0} \Delta \dot{\delta}_i + \sum_{j=1}^{2n-m} \left( \frac{\partial L_{i,j}^G}{\partial \delta_i} + L_{i,j}^B + L_{i,j}^{Pbus} \right) \Delta z_j = 0 \quad i = 1, \dots, m \quad (13)$$

$$(2G_{ii} V_i) \Delta V_i + \sum_{j=1}^{2n-m} \left( \frac{\partial L_{i,j}^G}{\partial \delta_i} + L_{i,j}^B + L_{i,j}^{Pbus} \right) \Delta z_j = 0 \quad i = m+1, \dots, n \quad (14)$$

$$\sum_{j=1}^{2n-m} \left( \frac{\partial L_{i,j}^G}{\partial \delta_{i-n+m}} + L_{i,j}^B + L_{i,j}^{Qbus} \right) \Delta z_j = 0 \quad i = n+1, \dots, 2n-m \quad (15)$$

where  $\mathbf{z}$  is the state vector of the system. It involves the voltage angle of all buses and voltage amplitudes of non-

generator buses as follows. Matrices  $\mathbf{L}^B, \mathbf{L}^G, \mathbf{L}^{Pbus}$ , and  $\mathbf{L}^{Qbus}$  are hessian matrices of energy functions  $R^B, R^G, R^{Pbus}$ , and  $R^{Qbus}$ , respectively. Dimensions of all matrices equal  $(2n - m) \times (2n - m)$ .

$$\mathbf{z} = [z_1 \dots z_{2n-m}] = [\delta_1 \dots \delta_n \ V_{m+1} \dots V_n] \quad (16)$$

#### A. Computing Hessian Matrices

For the convenience of calculating matrices  $\mathbf{L}^B$  and  $\mathbf{L}^G$ , the following variable transformation is used:

$$\boldsymbol{\theta} = [\theta_1, \dots, \theta_l] = [\delta_1, \dots, \delta_n] \times \mathbf{A} \quad (17)$$

$$\mathbf{v} = [v_1, \dots, v_l] = [\ln V_1, \dots, \ln V_n] \times |\mathbf{A}| \quad (18)$$

where  $\mathbf{A}$  matrix is the incidence matrix of the power system, and  $l$  is the number of transmission lines.

Using (17) and (18), the energy functions  $R^B$  and  $R^G$  are rewritten in terms of the new state variables as follows, and then all hessian matrices are calculated as (21)-(22).

$$R^B = -\sum_{k=1}^l B_k e^{v_k} \cos(\theta_k) \quad (19)$$

$$R^G = \sum_{k=1}^l G_k e^{v_k} \cos(\theta_k) \quad (20)$$

$$\mathbf{L}^B = \mathbf{H}^T \begin{bmatrix} \frac{\partial^2 R^B}{\partial \theta^2} & \frac{\partial^2 R^B}{\partial \theta \partial v} \\ \frac{\partial^2 R^B}{\partial v \partial \theta} & \frac{\partial^2 R^B}{\partial v^2} \end{bmatrix} \mathbf{H} + \begin{bmatrix} \mathbf{0}_{n \times n} & \mathbf{0}_{n \times (n-m)} \\ \mathbf{0}_{(n-m) \times n} & \mathbf{L}^{Bdiag} \end{bmatrix} \quad (21)$$

$$\mathbf{L}^G = \mathbf{H}^T \begin{bmatrix} \frac{\partial^2 R^G}{\partial \theta^2} & \frac{\partial^2 R^G}{\partial \theta \partial v} \\ \frac{\partial^2 R^G}{\partial v \partial \theta} & \frac{\partial^2 R^G}{\partial v^2} \end{bmatrix} \mathbf{H} + \begin{bmatrix} \mathbf{0}_{n \times n} & \mathbf{0}_{n \times (n-m)} \\ \mathbf{0}_{(n-m) \times n} & \mathbf{L}^{Gdiag} \end{bmatrix} \quad (22)$$

where:

$$\frac{\partial^2 R^B}{\partial \theta^2} = -\frac{\partial^2 R^B}{\partial v^2} = \text{diag} \{B_1 E_1, \dots, B_l E_l\} \quad (23)$$

$$\frac{\partial^2 R^B}{\partial \theta \partial v} = \frac{\partial^2 R^B}{\partial v \partial \theta} = \text{diag} \{B_1 F_1, \dots, B_l F_l\} \quad (24)$$

$$[\mathbf{L}^{Bdiag}]_{i,j} = \begin{cases} \sum_{k=1}^l \frac{|A(i+m,k)|}{V_{i+m}^2} \times B_k E_k & i = j = 1, \dots, n-m \\ 0 & \text{otherwise} \end{cases} \quad (25)$$

$$\frac{\partial^2 R^G}{\partial \theta^2} = -\frac{\partial^2 R^G}{\partial v^2} = -\text{diag} \{G_1 E_1, \dots, G_l E_l\} \quad (26)$$

$$\frac{\partial^2 R^G}{\partial \theta \partial v} = \frac{\partial^2 R^G}{\partial v \partial \theta} = -\text{diag} \{G_1 F_1, \dots, G_l F_l\} \quad (27)$$

$$[\mathbf{L}^{Gdiag}]_{i,j} = \begin{cases} -\sum_{k=1}^l \frac{|A(i+m,k)|}{V_{i+m}^2} \times G_k E_k & i = 1, \dots, n-m \\ 0 & j = i \\ & \text{otherwise} \end{cases} \quad (28)$$

$$E_k = e^{v_k} \cos(\theta_k) \quad (29)$$

$$F_k = e^{i\theta_k} \sin(\theta_k) \quad (30)$$

$$\mathbf{H} = \begin{bmatrix} \mathbf{A}^T & \mathbf{0}_{l \times (n-m)} \\ \mathbf{0}_{l \times n} & \begin{bmatrix} |A_{m+1,1}| & \dots & |A_{m+1,l}| \\ V_{m+1} & \dots & V_{m+1} \\ \vdots & \dots & \vdots \\ |A_{n,1}| & \dots & |A_{n,l}| \\ V_n & \dots & V_n \end{bmatrix}^T \end{bmatrix} \quad (31)$$

where  $\mathbf{L}^{Pbus}$  and  $\mathbf{L}^{Qbus}$  are simplicity obtained using second-order derivatives in terms of the original state variables as follows:

$$\begin{aligned} [\mathbf{L}^{Pbus}]_{i,j} &= \begin{bmatrix} \mathbf{0}_{(2n-m) \times m} & \left[ \frac{\partial^2 R^{Pbus}}{\partial \mathbf{z}^2} \right]^T & \mathbf{0}_{(2n-m) \times (n-m)} \end{bmatrix}^T \\ &= \begin{cases} \begin{pmatrix} -P_{i_0} \\ V_{i_0} \end{pmatrix} \times \begin{pmatrix} k_{pl} + 2k_{pz} \frac{V_i}{V_{i_0}} \\ V_{i_0} \end{pmatrix} & i = m+1, \dots, n \\ 0 & j = n+1, \dots, 2n-m \\ 0 & \text{otherwise} \end{cases} \end{aligned} \quad (32)$$

$$\begin{aligned} [\mathbf{L}^{Qbus}]_{i,j} &= \begin{bmatrix} \mathbf{0}_{(2n-m) \times n} & \left[ \frac{\partial^2 R^{Qbus}}{\partial \mathbf{z}^2} \right]^T \end{bmatrix}^T \\ &= \begin{cases} \begin{pmatrix} -B_{i-n+m, i-n+m} + \\ Q_{(i-n+m)_0} \begin{pmatrix} -\frac{k_{QZ}}{V_{(i-n+m)_0}^2} \\ +\frac{k_{QC}}{V_{i-n+m}^2} \end{pmatrix} \end{pmatrix} & i = j = \\ & n+1, \dots, 2n-m \\ 0 & \text{otherwise} \end{cases} \end{aligned} \quad (33)$$

### B. Modal Analysis using Quadratic Polynomial Matrix (QPM)

Finally, if the set of equations are arranged in the matrix form, then the following equation is obtained.

$$\mathbf{M}\Delta\ddot{\mathbf{z}} + \mathbf{D}\Delta\dot{\mathbf{z}} + (\mathbf{L}^V + \mathbf{L}^{G\delta} + \mathbf{L}^B + \mathbf{L}^{Pbus} + \mathbf{L}^{Qbus})\Delta\mathbf{z} = \mathbf{0} \quad (34)$$

where:

$$\mathbf{M} = \frac{\text{diag}\{2h_1, \dots, 2h_m, \mathbf{0}_{1 \times (2n-2m)}\}}{\omega_0} \quad (35)$$

$$\mathbf{D} = \frac{\text{diag}\{d_{G_1}, \dots, d_{G_m}, \mathbf{0}_{1 \times (2n-2m)}\}}{\omega_0} \quad (36)$$

$$\mathbf{L}^V = \text{diag}\{\mathbf{0}_{1 \times m}, 2G_{nm+1}V_{m+1}, \dots, 2G_mV_n, \mathbf{0}_{1 \times (n-m)}\} \quad (37)$$

$$\mathbf{L}^{G\delta} = \left[ (\mathbf{L}_1^{G\delta 1})^T, \dots, (\mathbf{L}_n^{G\delta 1})^T, (\mathbf{L}_{n+1}^{G\delta 2})^T, \dots, (\mathbf{L}_{2n-m}^{G\delta 2})^T \right]^T \quad (38)$$

$$\mathbf{L}_i^{G\delta 1} = \begin{bmatrix} \frac{\partial L_{i,1}^G}{\partial \delta_i} & \dots & \frac{\partial L_{i,2n-m}^G}{\partial \delta_i} \end{bmatrix} \quad i = 1, \dots, n \quad (39)$$

$$\mathbf{L}_i^{G\delta 2} = \begin{bmatrix} \frac{\partial L_{i,1}^G}{\partial \delta_{i-n+m}} & \dots & \frac{\partial L_{i,2n-m}^G}{\partial \delta_{i-n+m}} \end{bmatrix} \quad i = n+1, \dots, 2n-m \quad (40)$$

The length of vectors  $\mathbf{L}_i^{G\delta 1}$  and  $\mathbf{L}_i^{G\delta 2}$  are  $2n - m$ . These vectors are calculated using the chain differential rule. According to this rule, the differential in terms of  $\delta$  is obtained in terms of  $\theta$  as follows:

$$\frac{\partial}{\partial \delta_i} = \sum_{k=1}^l \frac{\partial}{\partial \theta_k} \frac{\partial \theta_k}{\partial \delta_i} = \sum_{k=1}^l H^T(i, k) \times \frac{\partial}{\partial \theta_k} \quad (41)$$

Consequently,  $\mathbf{L}_i^{G\delta 1}$  and  $\mathbf{L}_i^{G\delta 2}$  are obtained as follows:

$$\mathbf{L}_i^{G\delta 1} = \mathbf{H}^T(i, :) \left( \sum_{k=1}^l H^T(i, k) \times \mathbf{L}_k^{Gq} \right) \mathbf{H} \quad (42)$$

$$\mathbf{L}_i^{G\delta 2} = \mathbf{H}^T(i, :) \left( \sum_{k=1}^l H^T(i-n+m, k) \times \mathbf{L}_k^{Gq} \right) \mathbf{H} + \mathbf{L}_i^{Gdiag-\delta} \quad (43)$$

$\mathbf{L}_i^{Gq}$  and  $\mathbf{L}_i^{Gdiag-\delta}$  are the  $2l \times 2l$  matrix and the  $1 \times 2(n - m)$  vector as:

$$[\mathbf{L}_k^{Gq}]_{i,j} = \begin{cases} G_k F_k & i = j = k \\ -G_k E_k & i = j - l = k \\ -G_k E_k & i = j + l = k + l \\ -G_k F_k & i = j = k + l \\ 0 & \text{otherwise} \end{cases} \quad (44)$$

$$[\mathbf{L}_i^{Gdiag-\delta}]_{1,j} = \begin{cases} \frac{\sum_{k=1}^l A(i-n+m, k) G_k F_k}{V_{i-n+m}^2} & i = j \\ 0 & \text{otherwise} \end{cases} \quad (45)$$

QPM is characterized as (46). The  $i^{th}$  eigenvalue of the system  $\lambda_i$ , and the corresponding right and left eigenvectors,  $\mathbf{X}$  and  $\mathbf{W}$ , are calculated by (47) and (48), respectively.

$$\mathbf{Q}(\lambda_i) = \mathbf{M}\lambda_i^2 + \mathbf{D}\lambda_i + \mathbf{L}^V + \mathbf{L}^{G\delta} + \mathbf{L}^B + \mathbf{L}^{Pbus} + \mathbf{L}^{Qbus} \quad (46)$$

$$\mathbf{Q}(\lambda_i) \times \mathbf{X} = \mathbf{0}_{(2n-m) \times 1} \quad (47)$$

$$\mathbf{W}^T \times \mathbf{Q}(\lambda_i) = \mathbf{0}_{1 \times (2n-m)} \quad (48)$$

Entries of the right and left eigenvectors are defined by (49) and (50), respectively. In the right eigenvector, entries  $x_1$  to  $x_n$  and  $x_{n+1}$  to  $x_{2n-m}$  are related to voltage angle state variables and amplitude of load bus voltage state variables, respectively. Similarly, this is true for the entries of the left eigenvector.

$$\begin{aligned} \mathbf{X} &= [x_{\delta_1} \quad \dots \quad x_{\delta_n} \quad x_{V_{m+1}} \quad \dots \quad x_{V_n}]^T \\ &= [x_1 \quad \dots \quad x_{2n-m}]^T \end{aligned} \quad (49)$$

$$\begin{aligned} \mathbf{W} &= [w_{\delta_1} \quad \dots \quad w_{\delta_n} \quad w_{V_{m+1}} \quad \dots \quad w_{V_n}]^T \\ &= [w_1 \quad \dots \quad w_{2n-m}]^T \end{aligned} \quad (50)$$

### Sensitivity Factors of the Electromechanical Mode

To calculate the sensitivities of eigenvalues concerning state variables, both sides of (47) is pre-multiplied by the left eigenvector  $\mathbf{W}^T$ , and the differential is taken from the resultant equation. By doing so, the following equations

is obtained:

$$d\lambda_i = -\frac{\mathbf{W}^T d(\mathbf{L}^{total}) \mathbf{X}}{\alpha} \quad (51)$$

where:

$$\mathbf{L}^{total} = \mathbf{L}^B + \mathbf{L}^{Pbus} + \mathbf{L}^{Qbus} + \mathbf{L}^V + \mathbf{L}^{G\delta} \quad (52)$$

$$\alpha = 2\lambda_i \mathbf{W}^T \mathbf{M} \mathbf{X} + \mathbf{W}^T \mathbf{D} \mathbf{X} \quad (53)$$

As can be seen in (51), the denominator is a constant value, whereas the numerator includes the differential of matrix  $\mathbf{L}^{total}$  that comprises five differential terms. The following subsections will provide corresponding formulae to calculate them.

### C. Calculation of $\mathbf{W}^T d(\mathbf{L}^B) \mathbf{X}$

For the sake of simplicity, right and left eigenvectors are defined in terms of new state variables as follows [27]:

$$\mathbf{X}' = [x_{\theta_1}, \dots, x_{\theta_l}, x_{v_1}, \dots, x_{v_l}]^T = \mathbf{H} \times \mathbf{X} \quad (54)$$

$$\mathbf{W}' = [w_{\theta_1}, \dots, w_{\theta_l}, w_{v_1}, \dots, w_{v_l}]^T = \mathbf{H} \times \mathbf{W} \quad (55)$$

Using the above equations,  $\mathbf{W}^T d(\mathbf{L}^B) \mathbf{X}$  is determined in the following:

$$\mathbf{W}^T d\mathbf{L}^B \mathbf{X} = \sum_{k=1}^l B_k \left\{ \begin{array}{l} (w_{v_k} x_{v_k} - w_{\theta_k} x_{\theta_k} - C_{L_k}) F_k \\ + (w_{\theta_k} x_{v_k} + w_{v_k} x_{\theta_k}) E_k \end{array} \right\} d\theta_k + \sum_{i=m+1}^n \sum_{k=1}^l |A(i, k)| B_k \left\{ \begin{array}{l} -\left[ \begin{array}{l} -(w_{v_k} - w_{v_i}^{ln}) \times \\ (x_{v_k} - x_{v_i}^{ln}) \\ + C_{L_k} + w_{\theta_k} x_{\theta_k} \\ - w_{v_i}^{ln} x_{v_i}^{ln} \end{array} \right] E_k \\ + \left[ \begin{array}{l} w_{\theta_k} (x_{v_k} - x_{v_i}^{ln}) \\ + x_{\theta_k} (w_{v_k} - w_{v_i}^{ln}) \end{array} \right] F_k \end{array} \right\} dV_i^{ln} \quad (56)$$

where:

$$dV_i^{ln} = \frac{dV_i}{V_i} \quad (57)$$

$$w_{v_i}^{ln} = \frac{w_{v_i}}{V_i} \quad (58)$$

$$x_{v_i}^{ln} = \frac{x_{v_i}}{V_i} \quad (59)$$

$$C_{L_k} = \sum_{i=m+1}^n |A(i, k)| (w_{v_i}^{ln} x_{v_i}^{ln}) \quad (60)$$

### D. Calculation of $\mathbf{W}^T d(\mathbf{L}^{Pbus}) \mathbf{X}$

After conducting some calculations, the following equation is derived.

$$\mathbf{W}^T d\mathbf{L}^{Pbus} \mathbf{X} = -2 \sum_{i=m+1}^n P_{i0} \left( \frac{V_i}{V_{i0}} \right)^2 k_{Pz} w_{\delta_i} x_{v_i}^{ln} dV_i^{ln} \quad (61)$$

### E. Calculation of $\mathbf{W}^T d(\mathbf{L}^{Qbus}) \mathbf{X}$

$\mathbf{W}^T d(\mathbf{L}^{Qbus}) \mathbf{X}$  is equal to:

$$\mathbf{W}^T d\mathbf{L}^{Qbus} \mathbf{X} = -2 \sum_{i=m+1}^n Q_{i0} k_{QC} w_{v_i}^{ln} x_{v_i}^{ln} dV_i^{ln} \quad (62)$$

### F. Calculation of $\mathbf{W}^T d(\mathbf{L}^V) \mathbf{X}$

$\mathbf{W}^T d(\mathbf{L}^V) \mathbf{X}$  is obtained as follows:

$$\mathbf{W}^T d\mathbf{L}^V \mathbf{X} = 2 \sum_{i=m+1}^n G_{ii} x_{\delta_i} w_{\delta_i} V_i dV_i^{ln} \quad (63)$$

### G. Calculation of $\mathbf{W}^T d(\mathbf{L}^{G\delta}) \mathbf{X}$

$\mathbf{L}^{G\delta}$  consists of sub-matrices  $\mathbf{L}^{G\delta 1} \mathbf{L}_i^{G\delta 1}$  and  $\mathbf{L}^{G\delta 2}$ . Therefore  $\mathbf{W}^T d(\mathbf{L}^{G\delta}) \mathbf{X}$  is obtained as shown in the following:

$$\mathbf{W}^T d\mathbf{L}^{G\delta} \mathbf{X} = \sum_{i=1}^n w_{\delta_i} d\mathbf{L}_i^{G\delta 1} \mathbf{X} + \sum_{i=n+1}^{2n-m} w_{V_{i-n+m}} d\mathbf{L}_i^{G\delta 2} \mathbf{X} \quad (64)$$

where:

$$w_{\delta_i} d\mathbf{L}_i^{G\delta 1} \mathbf{X} = w_{\delta_i} \sum_{k=1}^l G_k |A(i, k)| \left\{ \begin{array}{l} x_{\theta_k} E_k + x_{v_k} F_k \end{array} \right\} d\theta_k + w_{\delta_i} \sum_{j=m+1}^n \sum_{k=1}^l G_k |A(i, k) A(j, k)| \left\{ \begin{array}{l} x_{\theta_k} F_k \\ - (x_{v_k} - x_{v_j}^{ln}) E_k \end{array} \right\} dV_j^{ln} \quad (65)$$

$$w_{V_{i-n+m}} d\mathbf{L}_i^{G\delta 2} \mathbf{X} = w_{V_{i-n+m}} \sum_{k=1}^l A(i-n+m, k) G_k \left\{ \begin{array}{l} x_{\theta_k} E_k + \\ (x_{v_k} - 2x_{v_{i-n+m}}^{ln}) F_k \end{array} \right\} dV_{i-n+m}^{ln} + w_{V_{i-n+m}} \sum_{k=1}^l A(i-n+m, k) G_k \left\{ \begin{array}{l} x_{\theta_k} F_k - \\ (x_{v_k} - x_{v_{i-n+m}}^{ln}) E_k \end{array} \right\} d\theta_k \quad (66)$$

$$-w_{V_{i-n+m}} \sum_{j=m+1}^n \left\{ \sum_{k=1}^l \left[ \begin{array}{l} |A(j, k)| \times A(i-n+m, k) \times \\ G_k \left( \begin{array}{l} x_{\theta_k} E_k + \\ (x_{v_k} - x_{v_j}^{ln} - x_{v_{i-n+m}}^{ln}) F_k \end{array} \right) \end{array} \right] \right\} dV_j^{ln}$$

### H. Calculation of Sensitivity Factors

In the previous sections, the changes in the electromechanical mode were obtained according to the changes in the state variables. With respect to (34), in steady-state condition, changes in state variables can be calculated in terms of power changes of generators using (67).

Because net active power injection of slack bus is included in (34), pseudo inverse of  $\mathbf{L}^{total}$  matrix i.e.  $(\mathbf{L}^{total})^\dagger$  is used

$$d\mathbf{z}^T = (\mathbf{L}^{total})^\dagger d [P_{G_1}, \dots, P_{G_m}, \mathbf{0}_{1 \times 2(n-m)}]^T \quad (67)$$

By integrating all obtained equations in matrix form,  $d\lambda_i$  in (34) can be expressed in terms of generators active power as follows:

$$\Delta\lambda_i = \frac{-1}{\alpha} \left[ S_{\theta_1}, \dots, S_{\theta_l}, S_{v_{m+1}}, \dots, S_{v_n} \right] \times \begin{bmatrix} \mathbf{A}^T & \mathbf{0}_{l \times (n-m)} \\ \mathbf{0}_{(n-m) \times l} & \mathbf{I}_{n-m} \end{bmatrix} \times \left( \mathbf{L}^{total} \right)^\dagger d \left[ P_{G_1}, \dots, P_{G_m}, \mathbf{0}_{2(n-m) \times 1} \right] = \left[ S_{P_1} \dots S_{P_m} \right] d \left[ P_{G_1}, \dots, P_{G_m} \right]^T \quad (68)$$

where  $S_{P_1}$  to  $S_{P_m}$  are sensitivity factors of the electromechanical mode related to variations of generators active power.

If the critical electromechanical mode is  $\lambda_i = \sigma + j\omega$  then its damping-ratio is defined as follows:

$$\zeta = \frac{-\sigma}{\sqrt{\sigma^2 + \omega^2}} \quad (69)$$

Partial differential equation of the electromechanical mode damping-ratio with respect to its arguments i.e.  $\sigma$  and  $\omega$  is equal to:

$$d\zeta = -\frac{\omega}{|\lambda|^3} (\omega d\sigma - \sigma d\omega) \quad (70)$$

Separating imaginary and real portions of (68) and substituting those into (70) yields:

$$d\zeta = -\frac{\omega}{|\lambda|^3} \left( \sum_i^m \begin{pmatrix} \omega \times \text{real} [S_{P_i}] \\ -\sigma \times \text{imag} [S_{P_i}] \end{pmatrix} dP_{G_i} \right) \quad (71)$$

Finally by defining new index  $Sen_{damp_i}$ , (71) can be rewritten as:

$$d\zeta = \sum_i^m Sen_{damp_i} dP_{G_i} \quad (72)$$

where:

$$Sen_{damp_i} = -\frac{\omega}{|\lambda|^3} \times (\omega \times \text{real} [S_{P_i}] - \sigma \times \text{imag} [S_{P_i}]) \quad (73)$$

$Sen_{damp_i}$  index represents the damping-ratio sensitivity with respect to active power changes of  $i^{th}$  generator. The larger absolute value of  $Sen_{damp_i}$ , the effect of changes in the active power of  $i^{th}$  generator on variation of the electromechanical mode damping-ratio is greater. Therefore, the generators can be sorted according to the damping-ratio sensitivity factor values, and the two generators that have the largest difference are selected for applying generation redispatch.

### Generators Redispatch Plan

Fig. 3 shows the proposed iterative plan for applying generators redispatch remedial action. At first, the initial operating points of generators active power are received from the load flow of the power system. The network losses are determined and its deviation is set to zero. Next, generators are redispatched using sensitivity

coefficients to satisfy the permissible damping-ratio limit  $DR_{sch}$ . To take economic considerations into account, since redispatching imposes additional costs on the operation of the system, variations in generators active power must be minimized.

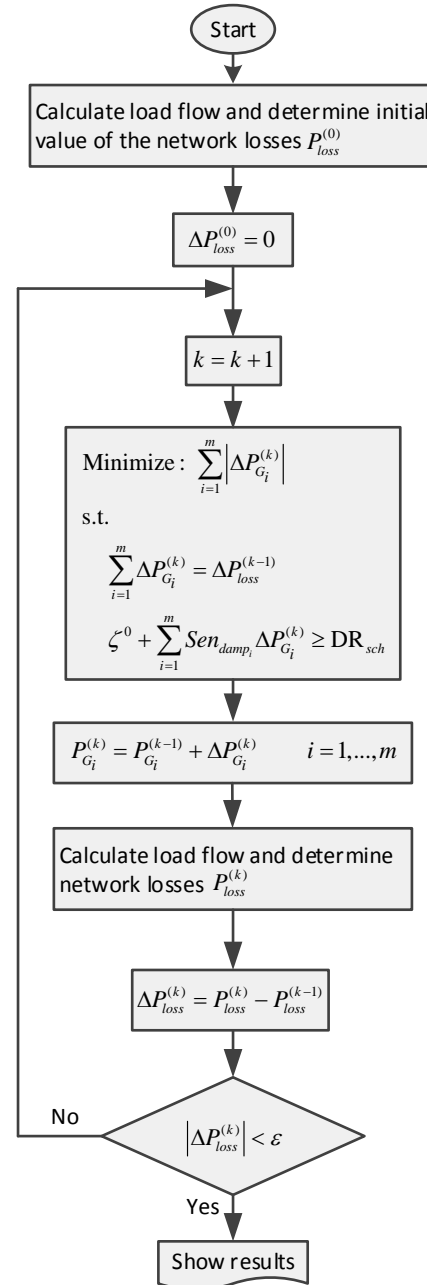

Fig. 3: Overview of the proposed generators redispatch scheme.

The greater the damping-ratio sensitivity factor associated with a generator, its active power changes lead to greater variations in the power system damping. Accordingly, generators with larger damping-ratio sensitivity factor are selected for redispatching in the proposed algorithm to satisfy the constraint of minimum power system damping with the least variations of



generators active power. Furthermore, since the resistance of the transmission lines is included in the modeling, the changes of network active power losses are considered in the generation redispatches to satisfy the balance of production and consumption in the system. To do so, the total active power variations of the generators must be equal to the variation of the network losses which is obtained from the previous iteration. After the optimization stage, the operating point of active power generators is updated and load flow is executed again. The amount of power network losses is calculated as the difference between the output active power of the generators and the consumption power of the loads. If the absolute value of the difference in power network losses between two consecutive steps is less than  $\epsilon$ , the iteration process ends. Otherwise, the value of  $\Delta P_{loss}$  is updated, and the process returns to the optimization step.

The bottleneck of real-world case studies is the need of transmission lines, synchronous generators, and load model data for modeling the proposed method. The exact amount of these data is usually not available and therefore a pre-processing step is needed to estimate them.

### Results and Discussion

In this section, the IEEE 39-bus test power system [40] shown in Fig. 4 is applied to evaluate the proposed formulae for determining the sensitivities of an electromechanical mode. The classical model of synchronous generators is used to investigate the effect of the load model and transmission lines resistance on the value of sensitivities. Two combinations of ZIP load model factors are tested and sensitivity factors along with optimal generators rediptach scheme are calculated.

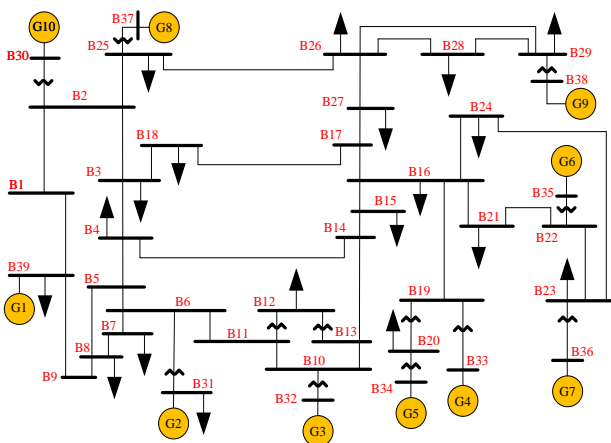

Fig. 4: IEEE 39-bus test power system.

#### 1. Constant Power Load

The test power system has an inter-area mode which is  $-0.0014 + 4.2218i$ . For this oscillatory mode,

generators 2 to 10 oscillate against generators 1. Table 1 lists sensitivity factors of the inter-area mode related to generators active power changes with considering and also neglecting the resistance of transmission lines. It is evident that changes in the active power of generators only influence the frequency of the inter-area mode and do not affect its real part. Nonetheless, changes in the frequency of the oscillatory mode, while keeping the real part constant, result in variations of its damping-ratio.

Table 1: Sensitivity factors corresponding to the electromechanical mode of interest considering constant power loads

Sensitivities	Considering transmission lines resistance	Neglecting transmission lines resistance
$S_{P1}$	$3.7 \times 10^{-5} + 0.1063i$	$-9.7 \times 10^{-7} + 0.0407i$
$S_{P2}$	$-4.68 \times 10^{-5} - 0.2612i$	$4.3 \times 10^{-6} - 0.0513i$
$S_{P3}$	$-3.99 \times 10^{-5} - 0.0795i$	$4.6 \times 10^{-7} - 0.0065i$
$S_{P4}$	$-7.91 \times 10^{-5} - 0.166i$	$-6.8 \times 10^{-6} - 0.0320i$
$S_{P5}$	$-7.99 \times 10^{-5} - 0.162i$	$-9.8 \times 10^{-6} - 0.0322i$
$S_{P6}$	$-5.58 \times 10^{-5} - 0.2656i$	$4.1 \times 10^{-6} - 0.0726i$
$S_{P7}$	$-6.12 \times 10^{-5} - 0.1483i$	$-9.3 \times 10^{-7} - 0.0321i$
$S_{P8}$	$-1.04 \times 10^{-4} - 0.1714i$	$-8.2 \times 10^{-6} - 0.0204i$
$S_{P9}$	$-1.2 \times 10^{-4} - 0.2089i$	$-8.4 \times 10^{-6} - 0.0228i$
$S_{P10}$	$8.9 \times 10^{-6} + 0.0269i$	$-2.2 \times 10^{-6} + 0.0098i$

Table 2 depicts  $Sen_{damp}$  indices. As seen in this table, their value with considering and neglecting transmission lines resistance are totally different. Moreover,  $Sen_{damp_2}$  and  $Sen_{damp_6}$  in the condition of considering transmission lines resistance are antiphase with their values in the condition of neglecting the resistances. Based on the calculated sensitivity factors considering transmission lines resistance, it is concluded that increasing the power of generators 2 and 6 lead to improve power system damping. However, neglecting lines resistance leads to an incorrect inference.

Table 3 arranges the values of the damping-ratio sensitivities in descending order. Let the redispatching plan is applied using a pair of generators  $(i, j)$  to improve power system damping.

Table 2: Electromechanical mode damping-ratio sensitivity factors corresponding to the electromechanical mode of interest considering constant power loads

No.	Considering transmission lines resistance	Neglecting transmission lines resistance
1	-1.71×10 <sup>-5</sup>	-0.29×10 <sup>-5</sup>
2	3.11×10 <sup>-5</sup>	-0.638×10 <sup>-5</sup>
3	1.55×10 <sup>-5</sup>	0.039×10 <sup>-5</sup>
4	3.14×10 <sup>-5</sup>	0.408×10 <sup>-5</sup>
5	3.13×10 <sup>-5</sup>	0.482×10 <sup>-5</sup>
6	3.35×10 <sup>-5</sup>	-0.417×10 <sup>-5</sup>
7	2.58×10 <sup>-5</sup>	0.269×10 <sup>-5</sup>
8	3.78×10 <sup>-5</sup>	0.353×10 <sup>-5</sup>
9	4.58×10 <sup>-5</sup>	0.376×10 <sup>-5</sup>
10	-0.418×10 <sup>-5</sup>	-0.023×10 <sup>-5</sup>

Table 3: Priority list of generators redispaches considering constant power loads

Rank	Considering transmission lines resistance	Neglecting transmission lines resistance
1	G9	G5
2	G8	G4
3	G6	G9
4	G4	G8
5	G5	G7
6	G2	G3
7	G7	G10
8	G3	G1
9	G10	G6
10	G1	G2

In the model of neglecting transmission lines resistance, the active power changes of both generators must be equal and in opposite directions to satisfy load balance constraint. Therefore, the damping-ratio variation is obtained as follows:

$$d\zeta = (Sen_{damp_i} - Sen_{damp_j}) dP_{G_i}$$

The greater the difference in the ranks of the selected generators, the absolute value of  $(Sen_{damp_i} - Sen_{damp_j})$  is greater, and therefore, redispatching the generators pair has more effect on improving the electromechanical mode damping-ratio. It can be inferred from Table 3 that if transmission lines resistance is neglected, generators pair 5 and 2 are the best options for redispatching. To do this, the active power of generator 5 must be increased, while the active power of generator 2 must be decreased.

The active power changes of the pair of generators are not equal when the resistance of transmission lines is considered. Nonetheless, the best choice for redispatching the pair of generators that have the greatest difference in their damping sensitivity coefficients. To do this, the active power of generator 9 must be increased, while the active power of generator 1 must be decreased. The proposed algorithm shown in Fig. 3 must be applied to determine new operating point of the generators pair active power.

In order to execute generators rediptach optimization problem which is shown in Fig. 2, it is assumed that generators can only change their initial power by 50%. Fig. 5 depicts the results of the proposed strategy with considering transmission lines resistance. The aim is to apply optimal generators redispatch to improve the damping-ratio of the mode of interest by 50%. The base power is 100 MVA. Active power of generator 9 is increased and generator 1 is decreased. The sum of absolute values of generators active power changes is equal to 5.09 pu.

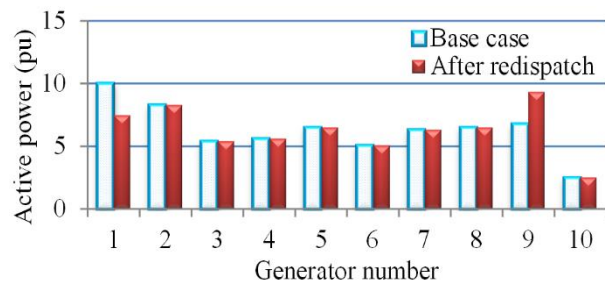

Fig. 5: Optimal generators redispaches plan considering constant power loads with considering transmission lines resistance.

It is important to emphasize that there is no feasible solution for achieving the goal when ignoring the resistance of transmission lines. Therefore, it is concluded that considering transmission lines resistance has a significant impact on the accuracy of sensitivities when the classical model of synchronous generators is used. In order to show quantitative insights into the effect of transmission lines resistance, it is assumed that the aim is applying optimal generators redispatch to improve the damping-ratio of the mode of interest by 25% of the initial value.

Table 4 compares required variations of generators active power with considering and neglecting transmission lines resistance. As seen in this table, sum of absolute values of generators active power changes with considering and neglecting transmission lines resistance are equal to 4.1 pu and 17.44 pu, respectively. Therefore, it is concluded that modeling the resistance of transmission lines has a significant impact on determining the pattern and amplitude of generators redispatch.

Table 4: Generators active power variations

Gen.	Considering transmission lines resistance	Neglecting transmission lines resistance
1	-2.03 pu	-2.04 pu
2	0	-4.14 pu
3	0	0
4	0	2.8 pu
5	0	3.24 pu
6	0	-2.54 pu
7	0	0
8	0	0
9	2.07 pu	2.68 pu
10	0	0
Sum of absolute deviations	4.1 pu	17.44 pu

J. Constant Current Load

To simulate constant current loads, the coefficients of ZIP load model in (4) and (5) are set as follows:

$$\begin{cases} k_{PI} = k_{QI} = 1 \\ k_{PC} = k_{PZ} = k_{QC} = k_{QZ} = 0 \end{cases}$$

In the corresponding modeling, the mode of interest is obtained as  $-0.0014 + 4.0019i$ . Comparing the calculated value of the electromechanical mode with its value in the condition of all loads are constant power type, it is concluded its frequency is decreased and its real part is not changed.

Tables 5 and 6 depict sensitivity factors and  $Sen_{damp}$  indices where all loads are constant current type. The priority list of generators active power redispatches for enhancing damping-ratio of the electromechanical mode is shown in Table 6.

Comparing Tables 2 and 6, it is inferred that the type of load model affects damping-ratio sensitivities. For example, the sign of  $Sen_{damp}$  index for generators 2 and 3 in the condition of constant current load with considering transmission lines resistance are different from ones in the condition of constant power load. Therefore, increasing active powers of generators 2 and 3 leads to improve damping-ratio of the electromechanical mode in condition of all loads are constant power, although these generators redispatches attenuate the mode damping.

Now, let's neglect transmission lines resistance, if all loads are constant power type, concerning the results shown in the right column of Table 3, redispatching generators pair 5 and 2 has the greatest effect on the variation of the mode damping-ratio.

Table 5: Sensitivity factors corresponding to the electromechanical mode of interest considering constant current loads

Sensitivities	Considering transmission lines resistance	Neglecting transmission lines resistance
$S_{P1}$	$7.27 \times 10^{-5} + 0.1588i$	$6.96 \times 10^{-6} + 0.0618i$
$S_{P2}$	$3.23 \times 10^{-5} - 0.0839i$	$4.18 \times 10^{-5} - 0.04004i$
$S_{P3}$	$1.76 \times 10^{-5} + 0.0393i$	$4.7 \times 10^{-7} + 0.01282i$
$S_{P4}$	$-1.46 \times 10^{-5} - 0.024i$	$-1.44 \times 10^{-5} - 0.0203i$
$S_{P5}$	$-1.64 \times 10^{-5} - 0.022i$	$-1.78 \times 10^{-5} - 0.0204i$
$S_{P6}$	$1.91 \times 10^{-5} - 0.0996i$	$2.97 \times 10^{-6} - 0.06801i$
$S_{P7}$	$-9.85 \times 10^{-7} - 0.0178i$	$-8.58 \times 10^{-6} - 0.023i$
$S_{P8}$	$-2.66 \times 10^{-5} - 0.0046i$	$-1.079 \times 10^{-5} + 0.0038i$
$S_{P9}$	$-3.8 \times 10^{-5} - 0.0182i$	$-1.08 \times 10^{-5} + 0.0042i$
$S_{P10}$	$4.92 \times 10^{-5} + 0.1004i$	$-6.1 \times 10^{-7} + 0.0269i$

Table 6: Electromechanical mode damping-ratio sensitivity factors corresponding to the electromechanical mode of interest considering constant current loads

No.	Considering transmission lines resistance	Neglecting transmission lines resistance
1	$-3.22 \times 10^{-5}$	$-0.734 \times 10^{-5}$
2	$-0.064 \times 10^{-5}$	$-0.691 \times 10^{-5}$
3	$-0.789 \times 10^{-5}$	$-0.128 \times 10^{-5}$
4	$0.582 \times 10^{-5}$	$0.5488 \times 10^{-5}$
5	$0.607 \times 10^{-5}$	$0.634 \times 10^{-5}$
6	$0.402 \times 10^{-5}$	$-0.133 \times 10^{-5}$
7	$0.1822 \times 10^{-5}$	$0.4244 \times 10^{-5}$
8	$0.706 \times 10^{-5}$	$0.2367 \times 10^{-5}$
9	$1.109 \times 10^{-5}$	$0.2343 \times 10^{-5}$
10	$-2.12 \times 10^{-5}$	$-0.2287 \times 10^{-5}$

However, in the condition where all loads are constant current type, with respecting the right column of Table 7, redispatching generators pair 5 and 1 has the greatest effect.

Therefore, the best pair of generators for redispatches is changed by varying the load model.

Table 7: Priority list of generators redispaches considering constant current loads

Rank	Considering transmission lines resistance	Neglecting transmission lines resistance
1	G9	G5
2	G8	G4
3	G5	G7
4	G4	G8
5	G6	G9
6	G7	G3
7	G2	G6
8	G3	G10
9	G10	G2
10	G1	G1

Fig. 6 shows the results of the proposed strategy for applying optimal generators redispach to improve the mode of interest damping-ratio by 50%, in the condition that all leads are constant current type. As seen in this figure, active powers of generators 8 and 9 increase while that of generator 1 decreases. The sum of absolute values of generators active power changes is equal to 8.38 pu, while it is equal to 5.09 pu in the condition that all loads are constant power type. Furthermore, generators 1, 8, and 9 are used for the optimal redispaching plan where all loads are constant current, while only generators 1 and 9 participate in the optimal redispaches plan where all loads are constant power. Therefore, the load model plays an outstanding role in determining sensitivity factors and the amplitude of generation redispaches, while it does not have a fundamental effect on changing the pattern of generators redispaches.

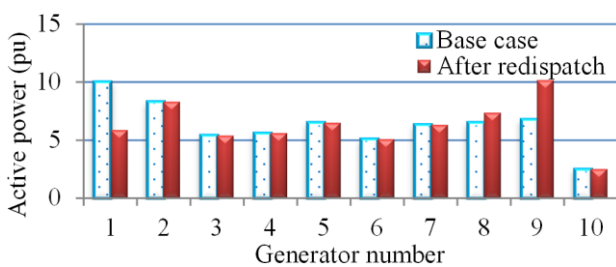

Fig. 6: Optimal generators redispaches plan considering constant current loads with considering transmission lines resistance.

**Conclusion**

This paper introduces a novel formula for determining the sensitivity of the damping-ratio of oscillatory modes with respect to active power of generators considering ZIP load model and resistance of power network transmission lines. The proposed formulae incorporate

the inertia and damping constants of generators, transmission line parameters, and both magnitude and angle of bus voltages. Since power system losses change with redispaches of generators, the iterative algorithm was suggested to achieve the optimal redispach plan when transmission lines resistance is modeled. The effectiveness of the proposed method for enhancing the damping-ratio of electromechanical modes is demonstrated through simulations of the 39-bus New England test system. The results show that load model and also considering transmission lines resistance are effective to determine the best generators redispach scheme.

This study serves as a preliminary exploration of the calculating damping-ratio sensitivities considering transmission lines resistance. Future research should be conducted considering more accurate generator models to calculate the precise effects of corrective actions on the damping changes of the system using the proposed model. Therefore, extending the proposed formula to encompass more comprehensive synchronous generator dynamic model, and power system security constraints in the generator redispach scheme are future research issues.

Nowadays, most loads are connected to the electric network through inverters. Therefore, Modeling of WECC composite load model by the proposed formulae must be examined. Furthermore, considering the proliferation of renewable energy resources (RES) and their role in power system stability, the development of the proposed formulae for modeling RES to identify optimal corrective actions are important topics for future researches.

**Author Contributions**

M. Setareh: Conceptualization, Investigation, Methodology, Simulation, Validation, Formal analysis, Writing manuscript.

A. Moradibirgani: Simulation, Formal analysis, Writing, Review & Editing.

**Acknowledgment**

We sincerely thank the respected referees for their accurate review of this paper.

**Conflict of Interest**

The authors declare no potential conflict of interest regarding the publication of this work. In addition, the ethical issues including plagiarism, informed consent, misconduct, data fabrication and, or falsification, double publication and, or submission, and redundancy have been completely witnessed by the authors.

**Abbreviations**

- GR Generator Redispatch
- HVDC High Voltage Direct Current

PSS	Power System Stabilizer
FACTS	Flexible Alternating Current Transmission Systems
SVC	Static Var Compensator
STATCOM	Static Compensators
TCSC	thyristor Controlled Series Capacitor
OPF	Optimal Power Flow
PMU	Phasor Measurement Units
QEP	Quadratic Eigenvalue Problem
NPF	Normalized Participation Factors
DAE	Dynamic-Algebraic Equations
PU	Per Unit
QPM	Quadratic Polynomial Matrix
RES	renewable Energy Resources

## References

- [1] M. J. Gibbard, P. Pourbeik, D. J. Vowles, *Small-signal stability, control and dynamic performance of power systems*, University of Adelaide press, 2015.
- [2] N. Hatzigiorgiou et al., "Definition and classification of power system stability - revisited & extended," *IEEE Trans. Power Syst.*, 36(4): 3271-3281, 2021.
- [3] P. M. Anderson, A. A. Fouad, *Power system control and stability*, second edition. John Wiley & Sons, 2002.
- [4] M. G. Jolfaei, A. M. Sharaf, S. M. Shariatmadar, M. B. Poudeh, "A hybrid PSS-SSSC GA-stabilization scheme for damping power system small signal oscillations," *Int. J. Electr. Power Energy Syst.*, 75: 337-344, 2016.
- [5] D. Wang, N. Ma, M. Wei, Y. Liu, "Parameters tuning of power system stabilizer PSS4B using hybrid particle swarm optimization algorithm," *Int. Trans. Electr. Energy Syst.*, 28(9): e2598, 2018.
- [6] M. Tadj et al., "Improved chaotic Bat algorithm for optimal coordinated tuning of power system stabilizers for multimachine power system," *Sci. Rep.*, 14(1): 15124, 2024.
- [7] A. T. Moghadam, M. Aghahadi, M. Eslami, S. Rashidi, B. Arandian, S. Nikolovski, "Adaptive rat swarm optimization for optimum tuning of svc and pss in a power system," *Int. Trans. Electr. Energy Syst.*, 2022, 4798029, 2022.
- [8] J. Zhou, D. Ke, C. Y. Chung, Y. Sun, "A computationally efficient method to design probabilistically robust wide-area PSSs for damping inter-area oscillations in wind-integrated power systems," *IEEE Trans. Power Syst.*, 33(5): 5692-5703, 2018.
- [9] T. Prakash, V. P. Singh, S. R. Mohanty, "A synchrophasor measurement based wide-area power system stabilizer design for inter-area oscillation damping considering variable time-delays," *Int. J. Electr. Power Energy Syst.*, 105: 131-141, 2019.
- [10] H. Zhao, Z. Lin, Q. Wu, S. Huang, "Model predictive control based coordinated control of multi-terminal HVDC for enhanced frequency oscillation damping," *Int. J. Electr. Power Energy Syst.*, 123, 106328, 2020.
- [11] W. Gao, R. Fan, R. Huang, Q. Huang, W. Gao, L. Du, "Augmented random search based inter-area oscillation damping using high voltage DC transmission," *Electr. Power Syst. Res.*, 216, 109063, 2023.
- [12] R. Huang, W. Gao, R. Fan, Q. Huang, "A guided evolutionary strategy based-static var compensator control approach for interarea oscillation damping," *IEEE Trans. Ind. Informatics*, 19(3): 2596-2607, 2023.
- [13] W. Peres, N. N. da Costa, "Comparing strategies to damp electromechanical oscillations through STATCOM with multi-band controller," *ISA Trans.*, 107: 256-269, 2020.
- [14] R. Huang, W. Gao, R. Fan, Q. Huang, "Damping inter-area oscillation using reinforcement learning controlled TCSC," *IET Gener. Transm. Distrib.*, 16(11): 2265-2275, 2022.
- [15] N. Nikolaev, K. Dimitrov, Y. Rangelov, "A comprehensive review of small-signal stability and power oscillation damping through photovoltaic inverters," *Energies*, 14(21): 7372, 2021.
- [16] J. L. Rodriguez-Amenedo, S. A. Gomez, "Damping low-frequency oscillations in power systems using grid-forming converters," *IEEE Access*, 9: 158984-158997, 2021.
- [17] W. Li, D. Cai, S. Wu, G. Zhang, F. Zhang, "The impact of supplementary active power control of wind turbine on power system low frequency oscillations," *Electr. Power Syst. Res.*, 224, 109746, 2023.
- [18] C. Yan, W. Yao, J. Wen, J. Fang, X. Ai, J. Wen, "Optimal design of probabilistic robust damping controllers to suppress multiband oscillations of power systems integrated with wind farm," *Renew. Energy*, 158: 75-90, 2020.
- [19] M. Basu, J. Kim, R. M. Nelms, E. Muljadi, "Coordination of utility-scale PV plant and wind power plant in interarea-oscillation damping," *IEEE Trans. Ind. Appl.*, 59(4): 4744-4751, 2023.
- [20] M. Hojabri, U. Dersch, A. Papaemmanouil, P. Bosshart, "A comprehensive survey on phasor measurement unit applications in distribution systems," *Energies*, 12(23): 4552, 2019.
- [21] A. D. Femine, D. Gallo, C. Landi, M. Luiso, "A design approach for a low cost phasor measurement unit," in *Proc. 2019 IEEE International Instrumentation and Measurement Technology Conference (I2MTC)*: 1-6, 2019.
- [22] J. Giri, "Proactive management of the future grid," *IEEE Power Energy Technol. Syst. J.*, 2(2): 243-52, 2015.
- [23] J. E. Condren, T. W. Gedra, "Expected-security-cost optimal power flow with small-signal stability constraints," *IEEE Trans. Power Syst.*, 21(4): 1736-1743, 2006.
- [24] T. Weckesser, H. Johannsson, J. Ostergaard, "Real-time remedial action against aperiodic small signal rotor angle instability," *IEEE Trans. Power Syst.*, 31(1): 387-396, 2016.
- [25] R. Zárate-Miñano, F. Milano, A. J. Conejo, "An OPF methodology to ensure small-signal stability," *IEEE Trans. Power Syst.*, 26(3): 1050-1061, 2011.
- [26] L. Yazdani, M. R. Aghamohammadi, "Damping inter-area oscillation by generation rescheduling based on wide-area measurement information," *Int. J. Electr. Power Energy Syst.*, 67: 138-151, 2015.
- [27] S. Mendoza-Armenta, I. Dobson, "Applying a formula for generator redispatch to damp interarea oscillations using synchrophasors," *IEEE Trans. Power Syst.*, 31(4): 3119-3128, 2016.
- [28] T. J. M. A. Parreiras, S. Gomes, G. N. Taranto, K. Uhlen, "Closest security boundary for improving oscillation damping through generation redispatch using eigenvalue sensitivities," *Electr. Power Syst. Res.*, 160: 119-127, 2018.
- [29] H. Golzari-Kolur, S. M.-T. Bathaee, T. Amraee, "A sequential generation redispatch algorithm to ensure power system small signal stability under low-frequency oscillations," *Int. Trans. Electr. Energy Syst.*, 2023: 1-15, 2023.
- [30] M. Khaji, M. R. Aghamohammadi, "Emergency transmission line

switching to suppress power system inter-area oscillation,” *Int. J. Electr. Power Energy Syst.*, 87: 52-64, 2017.

- [31] M. Setareh, M. Parniani, “Sensitivity-based optimal remedial actions to damp oscillatory modes considering security constraints,” *Int. J. Electr. Power Energy Syst.*, 135, 107580, 2022.
- [32] Y. Li, G. Geng, Q. Jiang, W. Li, X. Shi, “A sequential approach for small signal stability enhancement with optimizing generation cost,” *IEEE Trans. Power Syst.*, 34(6): 4828-4836, 2019.
- [33] H. Panahi, M. Abedini, M. Sanaye-Pasand, “Enhancing situation awareness by determining critical intra-area and interarea transmission lines,” *IEEE Syst. J.*, 17(4): 6192-6201, 2023.
- [34] K. N. Hasan, R. Preece, J. V. Milanovic, “Priority ranking of critical uncertainties affecting small-disturbance stability using sensitivity analysis techniques,” *IEEE Trans. Power Syst.*, 32(4): 2629-2639, 2017.
- [35] M. Setareh, M. Parniani, “Sensitivity-based generators redispatch to improve electromechanical mode damping considering transmission lines resistance,” in *Proc. 27th Iranian Conference on Electrical Engineering*: 491-496, 2019.
- [36] P. W. Sauer, M. A. Pai, J. H. Chow, *Power System Dynamics and Stability: With Synchrophasor Measurement and Power System Toolbox 2e*. Chichester, UK: John Wiley & Sons, Ltd, 2017.
- [37] M. Bircan, A. Durusu, B. Kekezoglu, O. Elma, U. S. Selamogullari, “Experimental determination of ZIP coefficients for residential appliances and ZIP model based appliance identification: The case of YTU Smart Home,” *Electr. Power Syst. Res.*, 179, 106070, 2020.
- [38] K. Veselić, *Damped oscillations of linear systems: A mathematical introduction*, in *The Model*: 1-13, Berlin: Springer Science & Business Media, 2011.
- [39] F. Tisseur, K. Meerbergen, “The quadratic eigenvalue problem,” *SIAM Rev.*, 43(2): 235-286, 2001.
- [40] I. Hiskens, “39-bus system (New England Reduced Model),” *IEEE PES Task Force on Benchmark Systems for Stability Controls*, Tech. Rep., PES TR18, 2013.

## Biographies



**Mohammad Setareh** received the B.Sc. degree from Iran University of Science and Technology, Tehran, Iran, in 2011, the M.Sc. degree from University of Tehran, Tehran, Iran, in 2013, and the Ph.D. degree from Sharif University of Technology, Tehran, Iran, in 2019, all in electrical power engineering. He is currently an Assistant Professor with the Faculty of Electrical Engineering at Shahid Beheshti University, Tehran, Iran. His research interests include power system stability, optimal power management in smart grid, wide area monitoring and control, and restructuring in power systems.

- Email: [m\\_setareh@sbu.ac.ir](mailto:m_setareh@sbu.ac.ir)
- ORCID: [0000-0002-1278-9876](https://orcid.org/0000-0002-1278-9876)
- Web of Science Researcher ID: AAF-1981-2019
- Scopus Author ID: 57202689177
- Homepage: [https://cpe.sbu.ac.ir/~m\\_setareh](https://cpe.sbu.ac.ir/~m_setareh)



**Alireza Moradibirgani** received the B.Sc. degree in Electrical Power Engineering from Shahid Chamran University of Ahvaz, Ahvaz, Iran, in 2023. He is currently working toward the M.Sc. degree with the Faculty of Electrical Engineering at Shahid Beheshti University, Tehran, Iran. His research interests include power systems, stability, power electronics, and electric vehicles.

- Email: [a.moradibirgani@mail.sbu.ac.ir](mailto:a.moradibirgani@mail.sbu.ac.ir)
- ORCID: [0009-0002-4801-1385](https://orcid.org/0009-0002-4801-1385)
- Web of Science Researcher ID: KXQ-5530-2024
- Scopus Author ID: NA
- Homepage: NA

### How to cite this paper:

M. Setareh, A. Moradibirgani, “Damping critical electromechanical oscillations via generators redispatch considering ZIP load model and transmission lines resistance,” *J. Electr. Comput. Eng. Innovations*, 13(2): 365-378, 2025.

DOI: [10.22061/jecei.2025.11106.766](https://doi.org/10.22061/jecei.2025.11106.766)

URL: [https://jecei.sru.ac.ir/article\\_2277.html](https://jecei.sru.ac.ir/article_2277.html)

